

GW5110

Triple Output AMOLED Display Power Management IC

Description

The GW5110 is designed to drive Active Matrix Organic Light Emitting Diode (AMOLED) displays requiring VAVDD, VELVDD and VELVSS. The device integrates a boost converter for VELVDD, an inverting buck-boost converter for VELVSS and a boost converter for VAVDD, which are suitable for battery operated products.

The digital interface control pin (SWIRE) allows programming of VAVDD, VELVDD and VELVSS. The GW5110 provides excellent line and load regulation by using a novel proprietary power management technology.

Features

- 2.9-V to 4.5-V Input Voltage Range
- Synchronous Boost Converter (AVDD)
 - 5.8V to 7.9V Output Voltage (programmable)
 - 6.1V Default Output Voltage
 - 1% Accuracy
 - 150mA Output Current Capability
- Synchronous Boost Converter (ELVDD)
 - 4.6V to 5.0V Output Voltage (programmable)
 - 4.6V Default Output Voltage
 - 1% Accuracy
 - 400mA Output Current Capability
 - External Output Voltage Sensing Pin for Load Drop Compensation
- Synchronous Inverting Buck-Boost Converter (ELVSS)
 - -5.4V to -1.4V Output Voltage (programmable)
 - -2.5V Default Output Voltage
 - 1.5% Accuracy
 - 400mA Output Current Capability
- Single-Wire Digital Interface for Programming
- Short Circuit Protection
- Thermal Shutdown

Physical Characteristics

- Input supply voltage, V_{DDP} : 2.9V to 4.5V
- ELVDD boost converter output voltage range: 4.6V ~ 5.0V
- ELVSS inverting buck-boost converter output voltage range: -5.4V ~ -1.4V
- AVDD boost converter output voltage range: 5.8V ~ 7.9V
- Operating junction temperature: -40°C to 125°C
- Available in 3mm x 3mm x 0.75mm 16-Pin WQFN Package

Typical Applications

- Smartphones
- Small Size Tablets
- AMOLED displays up to 8"

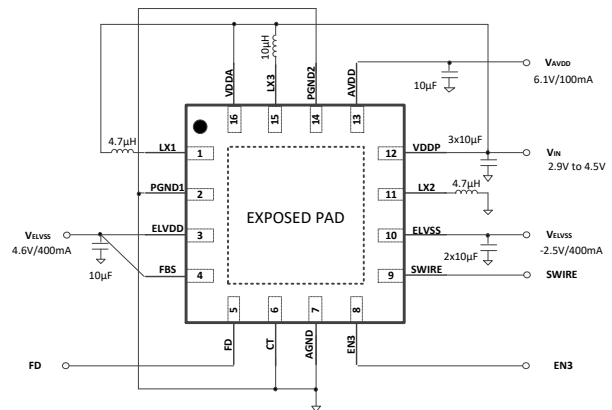

Basic Application Diagram

Ordering Information

Device name	Package	Remark
GW5110_Q16	16WQFN, 0.75mm pitch 3x3 body	

Block Diagram

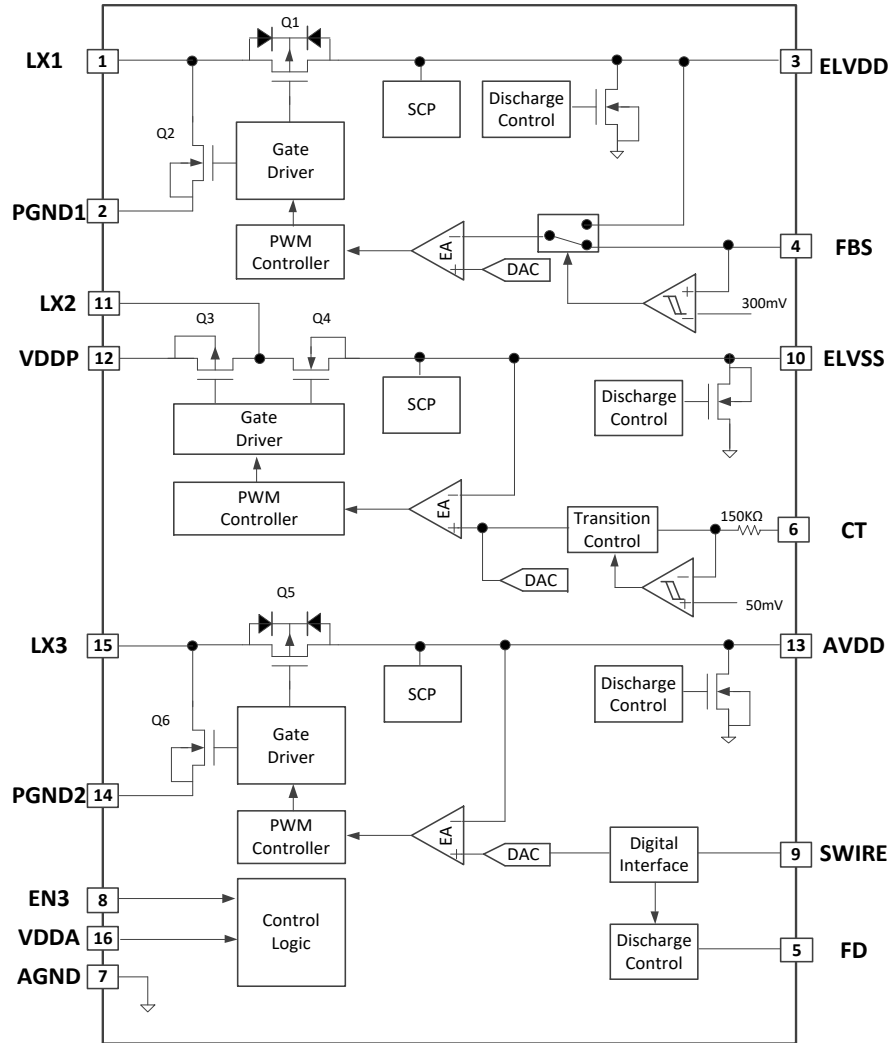

Package Information

Top View

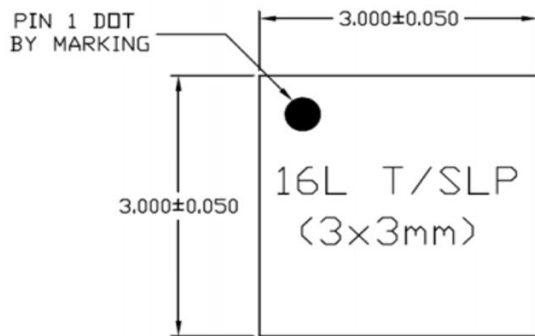

Bottom View

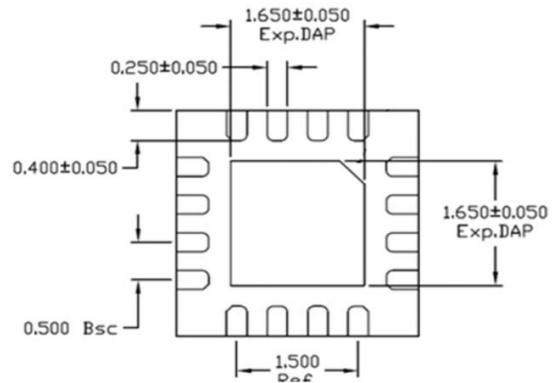

Notice

1. The descriptions of circuits, software, and other related information in this document are solely meant to demonstrate how semiconductor products operate and provide examples of their applications. You hold complete responsibility for incorporating or using the circuits, software, and information in designing your own product or system.
2. Gwanak Analog takes no responsibility for any losses or damages suffered by you or third parties resulting from the utilization of these circuits, software, or information.
3. Gwanak Analog explicitly disclaims any responsibility or liability for infringement or any other claims related to patents, copyrights, or other intellectual property rights of third parties, resulting from the use of Gwanak Analog products or technical information described in this document. This includes, but is not limited to, product data, drawings, charts, programs, algorithms, and application examples.
4. This document does not grant any form of license, whether explicit, implicit, or otherwise, under any patents, copyrights, or other intellectual property rights owned by Gwanak Analog or any other party.
5. It is your responsibility to identify and obtain any necessary licenses from third parties for the legal import, export, manufacturing, sales, use, distribution, or any other actions involving products that incorporate Gwanak Analog products, if such licenses are required.
6. You are prohibited from making any changes, modifications, copies, or reverse engineering of Gwanak Analog products, whether partially or entirely. Gwanak Analog takes no responsibility for any losses or damages suffered by you or third parties resulting from such actions of alteration, modification, copying, or reverse engineering.
7. No semiconductor product can guarantee absolute security. Despite any security measures or features incorporated into Gwanak Analog hardware or software products, Gwanak Analog holds no liability for any vulnerabilities or security breaches, including unauthorized access or usage of Gwanak Analog products or systems utilizing them. Gwanak Analog does not provide assurance or guarantee that Gwanak Analog products or systems created with them will be immune to issues like corruption, attacks, viruses, interference, hacking, data loss or theft, or other security intrusions. Gwanak Analog disclaims all responsibility and liability associated with vulnerability issues. Additionally, to the extent permitted by applicable law, Gwanak Analog disclaims all warranties, whether expressed or implied, regarding this document and any related software or hardware, including but not limited to warranties of merchantability or fitness for a particular purpose.
8. While Gwanak Analog strives to enhance the quality and reliability of its products, semiconductor products possess inherent characteristics, such as a certain failure rate and potential malfunctions under specific usage conditions. Unless explicitly specified as high-reliability products or intended for harsh environments in Gwanak Analog data sheets or other official documents, Gwanak Analog products do not incorporate radiation-resistant design. It is your responsibility to implement safety precautions to mitigate the risk of bodily harm, injuries, damage, or public hazards resulting from failures or malfunctions of Gwanak Analog products. These safety measures may include hardware and software safety design, such as redundancy, fire control, malfunction prevention, appropriate measures to address aging degradation, or other suitable actions. Since evaluating microcomputer software independently is challenging and impractical, you are accountable for assessing the safety of the final products or systems manufactured by you.
9. For specific information regarding environmental concerns related to Gwanak Analog products, kindly get in touch with a Gwanak Analog sales office. It is your responsibility to conduct a thorough investigation and ensure compliance with relevant laws and regulations pertaining to the usage or inclusion of controlled substances, including but not limited to the EU RoHS Directive. Gwanak Analog takes no responsibility for any damages or losses incurred due to your failure to comply with applicable laws and regulations.
10. Gwanak Analog products and technologies must not be utilized or included in any products or systems that are prohibited by domestic or foreign laws or regulations. You are required to adhere to export control laws and regulations imposed by governments of countries that assert jurisdiction over the parties involved or the transactions taking place.
11. The buyer, distributor, or any party involved in the distribution, sale, or transfer of Gwanak Analog products to a third party is responsible for informing the third party in advance about the contents and conditions specified in this document.
12. The content of this document cannot be reproduced, copied, or duplicated, either fully or partially, without obtaining prior written consent from Gwanak Analog.
13. If you have any inquiries about the information provided in this document or Gwanak Analog products, please reach out to a Gwanak Analog sales office for assistance.

Corporate Headquarters

Gwanak Analog Co., Ltd., 1 Gwanak-ro, Gwanak-gu,
Seoul National University Research Park, FL 5, Seoul,
Korea 08826

Contact Information

For further information on a product, technology, the most up-to-date version of a document, or your nearest sales office, please visit:
www.gwanakanalog.com

Trademarks

Gwanak Analog and Gwanak Analog logo are trademarks of Gwanak Analog Company. All trademarks and registered trademarks are the property of their respective owners.