

# GW2110

## Synthetic Signal Processing SoC with TTS for Edge AI Applications

### Description

The GW2110 is an advanced Synthetic Signal Processing SoC designed specifically for Edge AI applications, offering Text-to-Speech (TTS) capabilities. Equipped with an on-chip Inference Accelerator (IX) based on cutting-edge CNN architecture and hardware activation functions optimized for efficient speech processing, this device can provide real-time TTS capabilities without relying on a cloud server.

Featuring multiple interfaces, including analog voltage input channels, the GW2110 seamlessly integrates with a variety of sensors. From gas sensors for detecting CO and CH<sub>4</sub> to pressure, temperature, and humidity sensors, it empowers intelligent and user-friendly environmental monitoring. Utilizing its internal Edge AI engine and speech processing, the GW2110 offers comprehensive environmental insights and data analysis, including sensor fusion capabilities.

### Features

- Real-time TTS processing without a cloud server
- Multilingual TTS support (English, Korean, and Chinese)
- Embedded Arm® Cortex®-M4F (180MHz)
- On-chip inference accelerator (IX)
  - Utilizes CNN architecture with hardware activation functions (tanh and ReLU)
  - 128 MACs/cycle @FP16 (46.08GFLOPS @FP16)
- Internal memory
  - 128KB Program Memory

- 256KB Data Memory
- 1MB Shared Memory with IX
- Versatile interfaces
  - UART/I2C/SPI
  - Audio output: DDAC
  - Digital mic input: PDM
  - 4-channel 12-bit SAR ADC
  - USB2.0 Full Speed
- Dual QSPI interfaces for external SPI NAND and SPI NOR Flash memory
- Power management with sleep, stop, and standby modes
  - Wake-up options: RTC, GPIO, PDM
- Integrated power management components: LDO, POR, BOD

### Physical Characteristics

- Operating voltages
  - External supply voltage: 3.3V
  - I/O supply voltage: 3.3V
  - Analog core voltage: 1.2V
  - Digital core voltage: 1.2V
- Operating temperature: -40°C ~ 85°C
- Available in 8x8 0.4mm pitch 68-QFN package

### Typical Applications

- Smart home automation
- Voice-controlled IoT devices
- Healthcare, medical, and industrial devices
- Environmental monitoring
- Retail, hospitality, and education
- Automotive and accessibility solutions
- Robotics and automation

### Basic Application Diagram

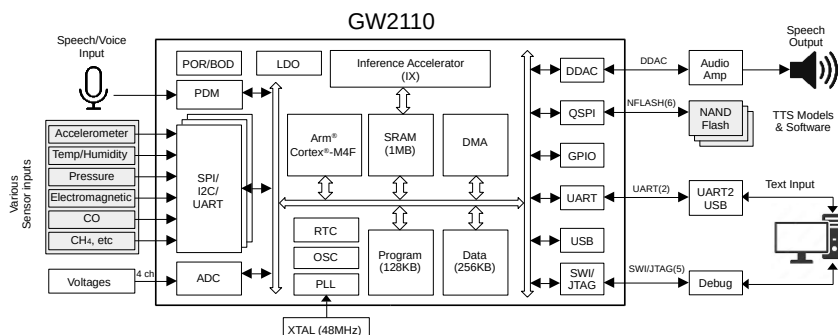

## Block Diagram

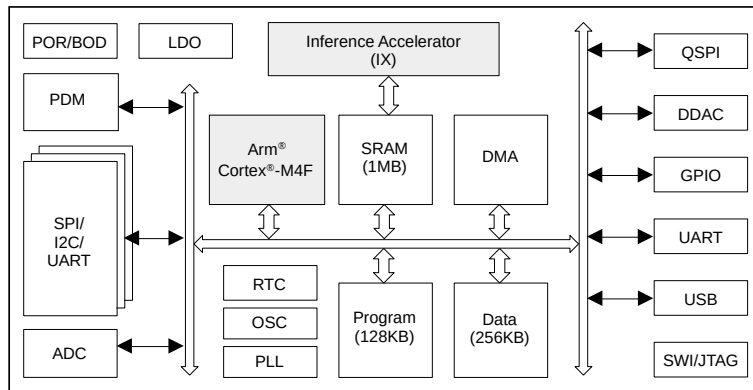

## Package Information

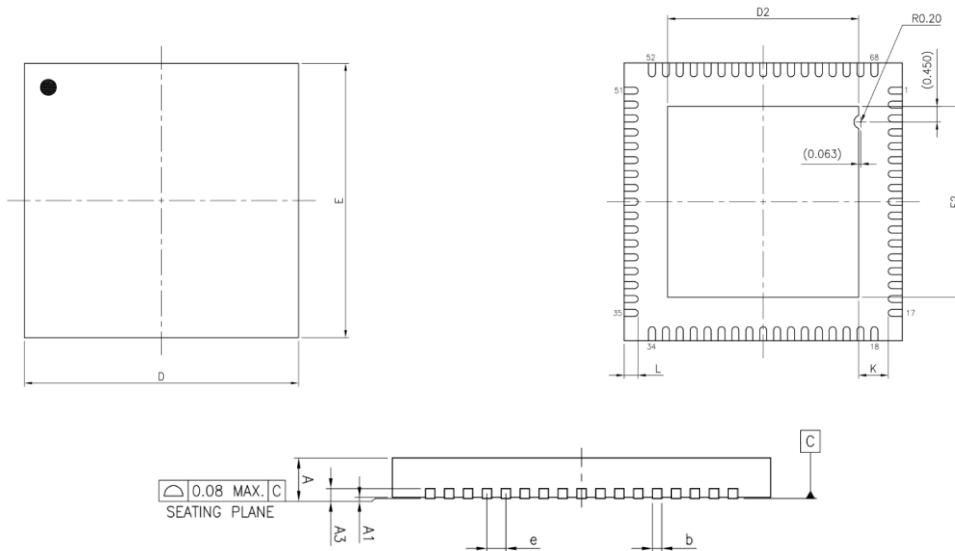

PACKAGE TYPE						
JEDEC OUTLINE	MO-220			MO-220		
PKG CODE	WQFN(X868)			VQFN(Y868)		
SYMBOLS	MIN.	NOM.	MAX.	MIN.	NOM.	MAX.
A	0.70	0.75	0.80	0.80	0.85	0.90
A1	0.00	0.02	0.05	0.00	0.02	0.05
A3	0.203 REF.		0.203 REF.			
b	0.15	0.20	0.25	0.15	0.20	0.25
D	7.90	8.00	8.10	7.90	8.00	8.10
E	7.90	8.00	8.10	7.90	8.00	8.10
e	0.40 BSC			0.40 BSC		
L	0.35	0.40	0.45	0.35	0.40	0.45
K	0.20	—	—	0.20	—	—

PAD SIZE	D2			E2			LEAD FINISH		JEDEC CODE
	MIN.	NOM.	MAX.	MIN.	NOM.	MAX.	Pure Tin	PPF	
236X23* MIL	5.45	5.50	5.55	5.45	5.50	5.55	V	X	N/A

## Ordering Information

Device name	Package	Remark
GW2110_Q68C	68QFN, 8x8, 0.4mm pitch	QFN68, Commercial
GW2110_Q68I	68QFN, 8x8, 0.4mm pitch	QFN68, Industrial

## Notice

1. The descriptions of circuits, software, and other related information in this document are solely meant to demonstrate how semiconductor products operate and provide examples of their applications. You hold complete responsibility for incorporating or using the circuits, software, and information in designing your own product or system.
2. Gwanak Analog takes no responsibility for any losses or damages suffered by you or third parties resulting from the utilization of these circuits, software, or information.
3. Gwanak Analog explicitly disclaims any responsibility or liability for infringement or any other claims related to patents, copyrights, or other intellectual property rights of third parties, resulting from the use of Gwanak Analog products or technical information described in this document. This includes, but is not limited to, product data, drawings, charts, programs, algorithms, and application examples.
4. This document does not grant any form of license, whether explicit, implicit, or otherwise, under any patents, copyrights, or other intellectual property rights owned by Gwanak Analog or any other party.
5. It is your responsibility to identify and obtain any necessary licenses from third parties for the legal import, export, manufacturing, sales, use, distribution, or any other actions involving products that incorporate Gwanak Analog products, if such licenses are required.
6. You are prohibited from making any changes, modifications, copies, or reverse engineering of Gwanak Analog products, whether partially or entirely. Gwanak Analog takes no responsibility for any losses or damages suffered by you or third parties resulting from such actions of alteration, modification, copying, or reverse engineering.
7. No semiconductor product can guarantee absolute security. Despite any security measures or features incorporated into Gwanak Analog hardware or software products, Gwanak Analog holds no liability for any vulnerabilities or security breaches, including unauthorized access or usage of Gwanak Analog products or systems utilizing them. Gwanak Analog does not provide assurance or guarantee that Gwanak Analog products or systems created with them will be immune to issues like corruption, attacks, viruses, interference, hacking, data loss or theft, or other security intrusions. Gwanak Analog disclaims all responsibility and liability associated with vulnerability issues. Additionally, to the extent permitted by applicable law, Gwanak Analog disclaims all warranties, whether expressed or implied, regarding this document and any related software or hardware, including but not limited to warranties of merchantability or fitness for a particular purpose.
8. While Gwanak Analog strives to enhance the quality and reliability of its products, semiconductor products possess inherent characteristics, such as a certain failure rate and potential malfunctions under specific usage conditions. Unless explicitly specified as high-reliability products or intended for harsh environments in Gwanak Analog data sheets or other official documents, Gwanak Analog products do not incorporate radiation-resistant design. It is your responsibility to implement safety precautions to mitigate the risk of bodily harm, injuries, damage, or public hazards resulting from failures or malfunctions of Gwanak Analog products. These safety measures may include hardware and software safety design, such as redundancy, fire control, malfunction prevention, appropriate measures to address aging degradation, or other suitable actions. Since evaluating microcomputer software independently is challenging and impractical, you are accountable for assessing the safety of the final products or systems manufactured by you.
9. For specific information regarding environmental concerns related to Gwanak Analog products, kindly get in touch with a Gwanak Analog sales office. It is your responsibility to conduct a thorough investigation and ensure compliance with relevant laws and regulations pertaining to the usage or inclusion of controlled substances, including but not limited to the EU RoHS Directive. Gwanak Analog takes no responsibility for any damages or losses incurred due to your failure to comply with applicable laws and regulations.
10. Gwanak Analog products and technologies must not be utilized or included in any products or systems that are prohibited by domestic or foreign laws or regulations. You are required to adhere to export control laws and regulations imposed by governments of countries that assert jurisdiction over the parties involved or the transactions taking place.
11. The buyer, distributor, or any party involved in the distribution, sale, or transfer of Gwanak Analog products to a third party is responsible for informing the third party in advance about the contents and conditions specified in this document.
12. The content of this document cannot be reproduced, copied, or duplicated, either fully or partially, without obtaining prior written consent from Gwanak Analog.
13. If you have any inquiries about the information provided in this document or Gwanak Analog products, please reach out to a Gwanak Analog sales office for assistance.

## Corporate Headquarters

Gwanak Analog Co., Ltd., 1 Gwanak-ro, Gwanak-gu,  
Seoul National University Research Park, FL 5, Seoul,  
Korea 08826

## Contact Information

For further information on a product, technology, the most up-to-date version of a document, or your nearest sales office, please visit:  
[www.gwanakanalog.com](http://www.gwanakanalog.com)

## Trademarks

Gwanak Analog and Gwanak Analog logo are trademarks of Gwanak Analog Company. All trademarks and registered trademarks are the property of their respective owners.